

新

NEW



Quick Change Polygon Threading Toolholders 快换多边形螺纹车刀杆

- Polygon shank
多边形类似山特维克CAPTO刀柄
- ISO standard (26623) compliant for toolholding systems
ISO标准 (26623) 夹持刀杆系列
- Polygon taper ensures automatic radial centering and even pressure around the coupling
多边形CAPTO锥度能给确保自动对准径向中心和周围连接
- Enable quick tool changes ISO standard coupling system with a 1.4-degree tapered polygon shank design
能够快速换刀的多边形ISO标准带一个1.4锥度的多边形连接柄设计
- Interchangeable with leading manufacturers
与先前制造的同类产品实现互换

快换多边形螺纹车刀柄

Quick Change Polygon Threading Toolholders

External Toolholders - Metric

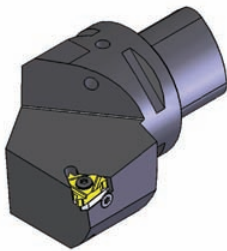

公制外刀杆

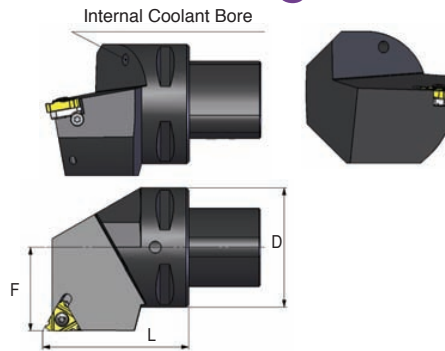

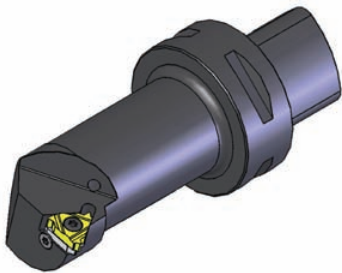

Ordering Code		D	F	L	Insert Screw	Anvil Screw	Torx key	RH Anvil	LH Anvil
P40-SER/L27050-16	16	40	27	50	S16	A16	K16	AE16	AI16
P50-SER/L35060-16	16	50	35	60	S16	A16	K16	AE16	AI16
P63-SER/L45065-16	16	63	45	65	S16	A16	K16	AE16	AI16
P40-SER/L27050-22	22	40	27	50	S22	A22	K22	AE22	AI22
P50-SER/L35060-22	22	50	35	60	S22	A22	K22	AE22	AI22
P63-SER/L45065-22	22	63	45	65	S22	A22	K22	AE22	AI22
P80-SER/L55080-22	22	80	55	80	S22	A22	K22	AE22	AI22

Internal Toolholders - Metric

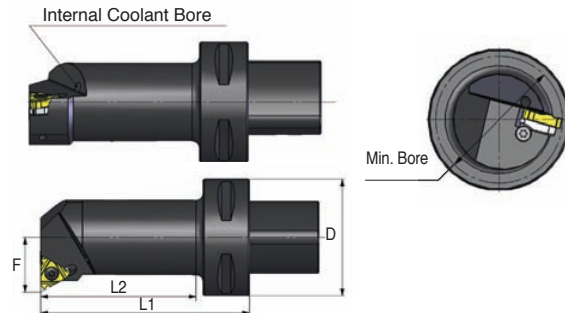

公制内刀杆



Ordering Code		D	F	Min. Bore Dia.	L1	L2	Insert Screw	Anvil Screw	Torx key	RH Anvil	LH Anvil
P40-SIR/L12060-16	16	40	12	20	60	37	S16	A16	K16	AI16	AE16
P40-SIR/L14060-16	16	40	14	25	60	38	S16	A16	K16	AI16	AE16
P40-SIR/L17070-16	16	40	17	32	70	48	S16	A16	K16	AI16	AE16
P40-SIR/L22090-16	16	40	22	40	90	69	S16	A16	K16	AI16	AE16
P40-SIR/L27080-16	16	40	27	50	80	60	S16	A16	K16	AI16	AE16
P50-SIR/L12060-16	16	50	12	20	60	35	S16	A16	K16	AI16	AE16
P50-SIR/L14060-16	16	50	14	25	60	36	S16	A16	K16	AI16	AE16
P50-SIR/L17070-16	16	50	17	32	70	47	S16	A16	K16	AI16	AE16
P50-SIR/L22090-16	16	50	22	40	90	68	S16	A16	K16	AI16	AE16
P50-SIR/L27105-16	16	50	27	50	105	84	S16	A16	K16	AI16	AE16
P63-SIR/L14070-16	16	63	14	25	70	42	S16	A16	K16	AI16	AE16
P63-SIR/L17075-16	16	63	17	32	75	48	S16	A16	K16	AI16	AE16
P63-SIR/L22090-16	16	63	22	40	90	64	S16	A16	K16	AI16	AE16
P63-SIR/L27105-16	16	63	27	50	105	80	S16	A16	K16	AI16	AE16
P40-SIR/L15065-22	22	40	15	25	65	42	S22	A22	K22	AI22	AE22
P40-SIR/L19070-22	22	40	19	32	70	48	S22	A22	K22	AI22	AE22
P40-SIR/L22090-22	22	40	22	40	90	69	S22	A22	K22	AI22	AE22
P40-SIR/L27080-22	22	40	27	50	80	60	S22	A22	K22	AI22	AE22
P50-SIR/L15065-22	22	50	15	25	65	41	S22	A22	K22	AI22	AE22
P50-SIR/L19070-22	22	50	19	32	70	47	S22	A22	K22	AI22	AE22
P50-SIR/L22090-22	22	50	22	40	90	68	S22	A22	K22	AI22	AE22
P50-SIR/L27105-22	22	50	27	50	105	84	S22	A22	K22	AI22	AE22
P63-SIR/L19075-22	22	63	19	32	75	48	S22	A22	K22	AI22	AE22
P63-SIR/L22090-22	22	63	22	40	90	64	S22	A22	K22	AI22	AE22
P63-SIR/L27105-22	22	63	27	50	105	80	S22	A22	K22	AI22	AE22

© Copyright CARMEX Precision Tools Ltd. 2012

CARMEX QC 09/2012 METRIC





1st Hacharoshet St., Maalot Industrial Zone 2101302, ISRAEL
 Tel: (972) 4-9077400, Fax: (972) 4-9077440.
 E-mail: info@carmex.com Website: www.carmex.com
 Postal address: P.O. Box 404, Maalot 2101302, ISRAEL.

Quick Change Polygon Threading Toolholders

External Toolholders - Metric

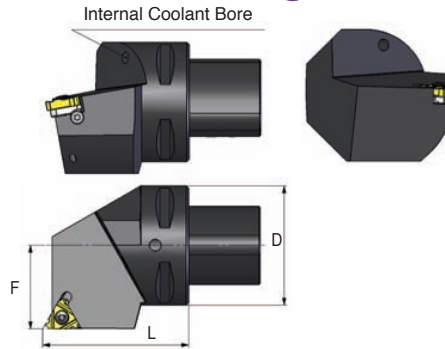
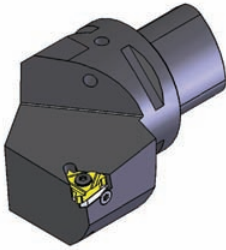
外刀杆公制



Ordering Code		D	F	L	Insert Screw	Anvil Screw	Torx key	RH Anvil	LH Anvil
P40-SER/L27050-16	16	40	27	50	S16	A16	K16	AE16	AI16
P50-SER/L35060-16	16	50	35	60	S16	A16	K16	AE16	AI16
P63-SER/L45065-16	16	63	45	65	S16	A16	K16	AE16	AI16
P40-SER/L27050-22	22	40	27	50	S22	A22	K22	AE22	AI22
P50-SER/L35060-22	22	50	35	60	S22	A22	K22	AE22	AI22
P63-SER/L45065-22	22	63	45	65	S22	A22	K22	AE22	AI22
P80-SER/L55080-22	22	80	55	80	S22	A22	K22	AE22	AI22

Internal Toolholders - Metric

内刀杆公制

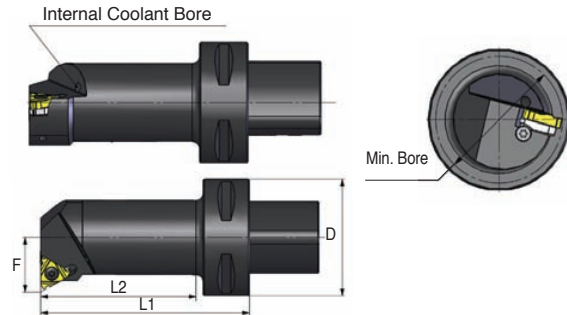
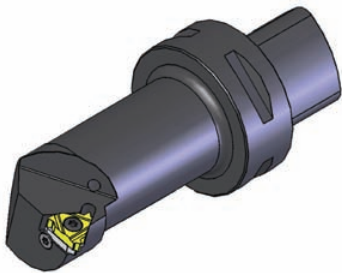

Ordering Code		D	F	Min. Bore Dia.	L1	L2	Insert Screw	Anvil Screw	Torx key	RH Anvil	LH Anvil
P40-SIR/L12060-16	16	40	12	20	60	37	S16	A16	K16	AI16	AE16
P40-SIR/L14060-16	16	40	14	25	60	38	S16	A16	K16	AI16	AE16
P40-SIR/L17070-16	16	40	17	32	70	48	S16	A16	K16	AI16	AE16
P40-SIR/L22090-16	16	40	22	40	90	69	S16	A16	K16	AI16	AE16
P40-SIR/L27080-16	16	40	27	50	80	60	S16	A16	K16	AI16	AE16
P50-SIR/L12060-16	16	50	12	20	60	35	S16	A16	K16	AI16	AE16
P50-SIR/L14060-16	16	50	14	25	60	36	S16	A16	K16	AI16	AE16
P50-SIR/L17070-16	16	50	17	32	70	47	S16	A16	K16	AI16	AE16
P50-SIR/L22090-16	16	50	22	40	90	68	S16	A16	K16	AI16	AE16
P50-SIR/L27105-16	16	50	27	50	105	84	S16	A16	K16	AI16	AE16
P63-SIR/L14070-16	16	63	14	25	70	42	S16	A16	K16	AI16	AE16
P63-SIR/L17075-16	16	63	17	32	75	48	S16	A16	K16	AI16	AE16
P63-SIR/L22090-16	16	63	22	40	90	64	S16	A16	K16	AI16	AE16
P63-SIR/L27105-16	16	63	27	50	105	80	S16	A16	K16	AI16	AE16
P40-SIR/L15065-22	22	40	15	25	65	42	S22	A22	K22	AI22	AE22
P40-SIR/L19070-22	22	40	19	32	70	48	S22	A22	K22	AI22	AE22
P40-SIR/L22090-22	22	40	22	40	90	69	S22	A22	K22	AI22	AE22
P40-SIR/L27080-22	22	40	27	50	80	60	S22	A22	K22	AI22	AE22
P50-SIR/L15065-22	22	50	15	25	65	41	S22	A22	K22	AI22	AE22
P50-SIR/L19070-22	22	50	19	32	70	47	S22	A22	K22	AI22	AE22
P50-SIR/L22090-22	22	50	22	40	90	68	S22	A22	K22	AI22	AE22
P50-SIR/L27105-22	22	50	27	50	105	84	S22	A22	K22	AI22	AE22
P63-SIR/L19075-22	22	63	19	32	75	48	S22	A22	K22	AI22	AE22
P63-SIR/L22090-22	22	63	22	40	90	64	S22	A22	K22	AI22	AE22
P63-SIR/L27105-22	22	63	27	50	105	80	S22	A22	K22	AI22	AE22

© Copyright CARMEX Precision Tools Ltd. 2012

CARMEX QC 09/2012 METRIC



Carmex Precision Tools LLC
 2075 Hwy 175, Richfield, WI 53076,
 Phone: 888 628-5030, Fax: 888 628-5302
 E-mail: sales@carmexusa.com Website: www.carmexusa.com